



CH51G SS PIN & BARREL SERIES

FULL MORTISE EDGE GUARD



Closed Position

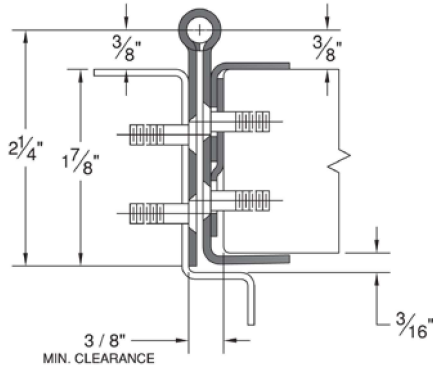

Open Position

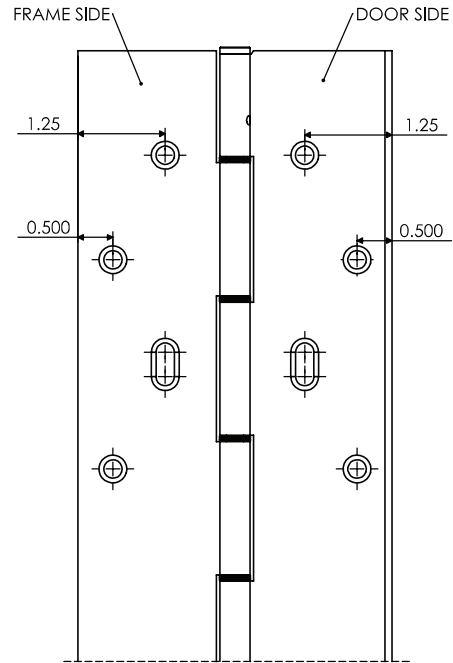
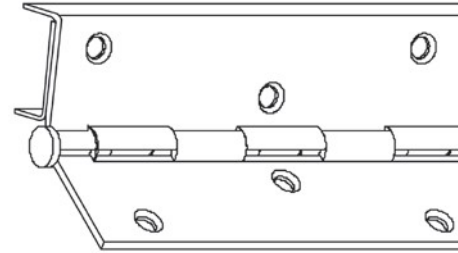
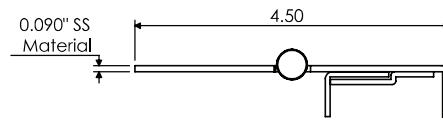
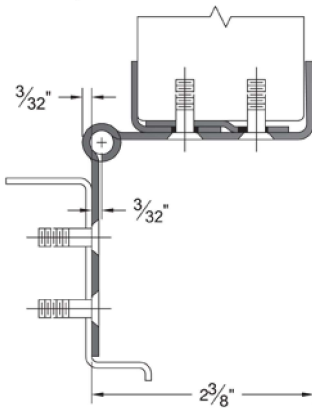

- ◆ For square edged doors
- ◆ For 1 3/4" doors
- ◆ Supports door weights up to 600 lbs.
- ◆ 4'0" Maximum door width
- ◆ For high traffic, high abuse doors
- ◆ No exposed fasteners when door is closed
- ◆ Fully reversible - No handing required.
- ◆ Material -Heavy-duty 13 gauge 304 Stainless Steel
- ◆ Self drilling screws
- ◆ 1/4" diameter stainless steel pin
- ◆ Adjustable to accommodate slight variances in door thickness
- ◆ Electrical modifications available
- ◆ Conforms to ANSI/BHMA 156.26, Grade 1
- ◆ UL/ULC fire listed on wood doors for up to 20 minutes
- ◆ UL/ULC fire listed on hollow metal & composite wood fire doors for 90 minutes
- ◆ UL/ULC fire listed on hollow metal doors for up to 3 hours
- ◆ Meets UL10B, UL10C, UBC 7-2.

PBB Model Number	Length		Screw Count	
	Inches	Centimeters	Door	Jamb
CH51G79	79-1/8"	201.0	20	20
CH51G83	83-1/8"	211.1	21	21
CH51G85	85"	215.9	21	21
CH51G95	95"	241.3	23	23
CH51G119	118-3/4"	301.6	27	27

630 - Satin Stainless Steel - US32D

Full Mortise Fasteners –

- a. Screw Pack 1 – 10 x 3/4" P.F.H. undercut self drilling tek screws
 - b. Screw Pack 2 - 10 x 1 1/4" P.F.H. undercut sheet metal screw
 - c. Screw Pack 5 - 10 - 32 x 3/4" P.F.H. undercut machine screw
- PLEASE SPECIFY SCREW PACK REQUIREMENTS



CH51G SS PIN & BARREL SERIES

STANDARD HINGE LENGTH CONVERSION CHART

FULL MORTISE EDGE GUARD

A 79.125 " ACTUAL LENGTH = A 6'8" DOOR OPENING	A 83.125" ACTUAL LENGTH = A 7' DOOR OPENING	A 85.00 " ACTUAL LENGTH = A 7'2" DOOR OPENING	A 95.00" ACTUAL LENGTH = A 8' DOOR OPENING	A 118.75" ACTUAL LENGTH = A 10' DOOR OPENING