

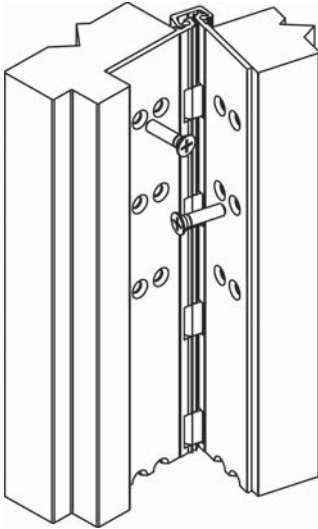

# CG31I HEAVY DUTY SERIES

## FULL MORTISE 1 1/8" INSET



Closed Position

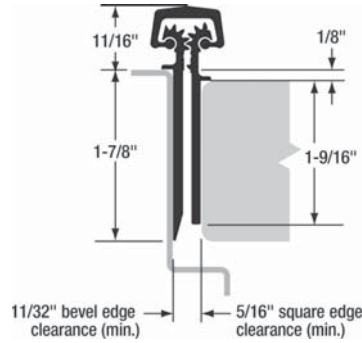

90° Open Position

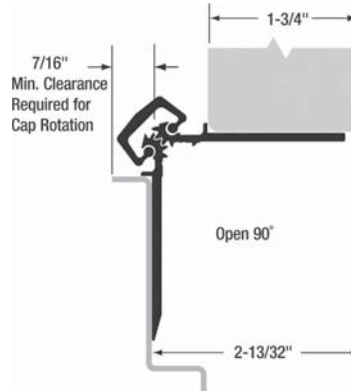

180° Open Position

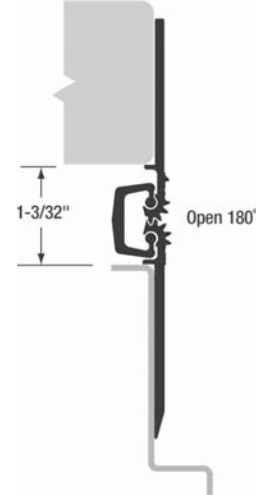

- ◆ For new construction
- ◆ 1/8" Inset
- ◆ For renovation with new doors and/or frames
- ◆ No mortising of doors or frames required
- ◆ Will cover butt hinge cut-outs in old frames
- ◆ Material - Extruded 6063-T6 Aluminum Alloy w / Polyester thrust bearings
- ◆ Can manufacturer hole sizes & locations per customers specs
- ◆ No door reinforcement required
- ◆ Over 200 lbs. reinforce frame with 16 Ga. Channel
- ◆ For 1 3/4" doors up to 450 lbs it meets ANSI/BHMA A156.26 2006 Grade 2.
- ◆ LL for doors up to 1000 lbs it meets ANSI/BHMA A156.26 2006 Grade 1.
- ◆ Template and hole pattern is same from hinge to hinge
- ◆ 83" can be field cut to 79" without cutting thru a bearing or mounting
- ◆ Hinge is non-handed unless cut in the field
- ◆ UL listed for 90 minute rated doors
- ◆ Can be UL listed for up to 3 hours

PBB Model Number	Length		Screw Count		LL Screw Count	
	Inches	Centimeters	Door	Jamb	Door	Jamb
CG31I83	83"	210.8	19	19	26	26
CG31I85	85"	215.9	19	19	26	26
CG31I95	95"	241.3	21	21	30	30
CG31I120	120"	304.8	23	23	34	34

628 - CLEAR ANODIZED - US28

710 - DARK ANODIZED - US10B

Full Mortise Fasteners-	
<p><b>Screw Pack A</b> #12-24 x 1/2" Phillips Flat Head Undercut Thread Forming Screws</p>	